

# **Flexible Manufacturing systems**

## **A. Bottleneck Model**

### **Lec 4**

**Dr. Mirza Jahanzaib**

# Where to Apply FMS Technology

- The plant presently either:
  - Produces parts in **batches** or
  - Uses **manned GT cells** and management wants to **automate the cells**
- It must be possible to **group a portion of the parts** made in the plant into part families
  - The part similarities allow them to be processed on the **FMS workstations**
- Parts and products are in the **mid-volume, mid-variety** production range

# Definition

A highly automated GT machine cell, consisting of a **group of processing stations** (usually CNC machine tools), interconnected by an **automated material handling and storage system**, and controlled by **an integrated computer system**

- The FMS relies on the principles of GT
  - No manufacturing system can produce an unlimited range of products
  - An FMS is capable of producing **a single part family** or a limited range of part families

# Flexibility Tests in an Automated Manufacturing System

To qualify as being flexible, a manufacturing system should satisfy the following criteria (“yes” answer for each question):

1. Can it process different part styles in a non-batch mode?
2. Can it accept changes in production schedule?
3. Can it respond gracefully to equipment malfunctions and breakdowns?
4. Can it accommodate introduction of new part designs?

# Automated Manufacturing Cell

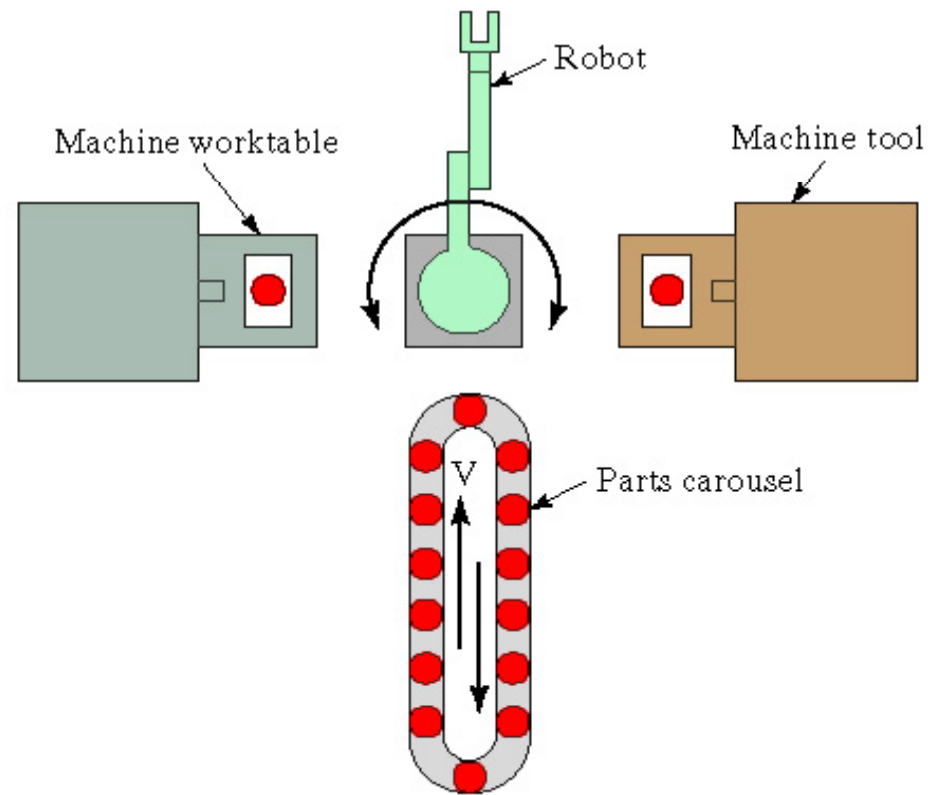

Automated manufacturing cell with two machine tools and robot. Is it a flexible cell?

# Is the Robotic Work Cell Flexible?

## 1. Part variety test

- Can it machine different part configurations in a mix rather than in batches?

## 2. Schedule change test

- Can production schedule and part mix be changed?

### 3. Error recovery test

- Can it operate if one machine breaks down?
  - Example: while repairs are being made on the broken machine, can its work be temporarily reassigned to the other machine?

### 4. New part test

- As new part designs are developed, can NC part programs be written off-line and then downloaded to the system for execution?

# Types of FMS

- Kinds of operations
  - Processing vs. assembly
  - Type of processing
    - If machining, rotational vs. non-rotational
- Number of machines (workstations):
  1. Single machine cell ( $n = 1$ )
  2. Flexible manufacturing cell ( $n = 2$  or  $3$ )
  3. Flexible manufacturing system ( $n = 4$  or more)



# Single-Machine Manufacturing Cell

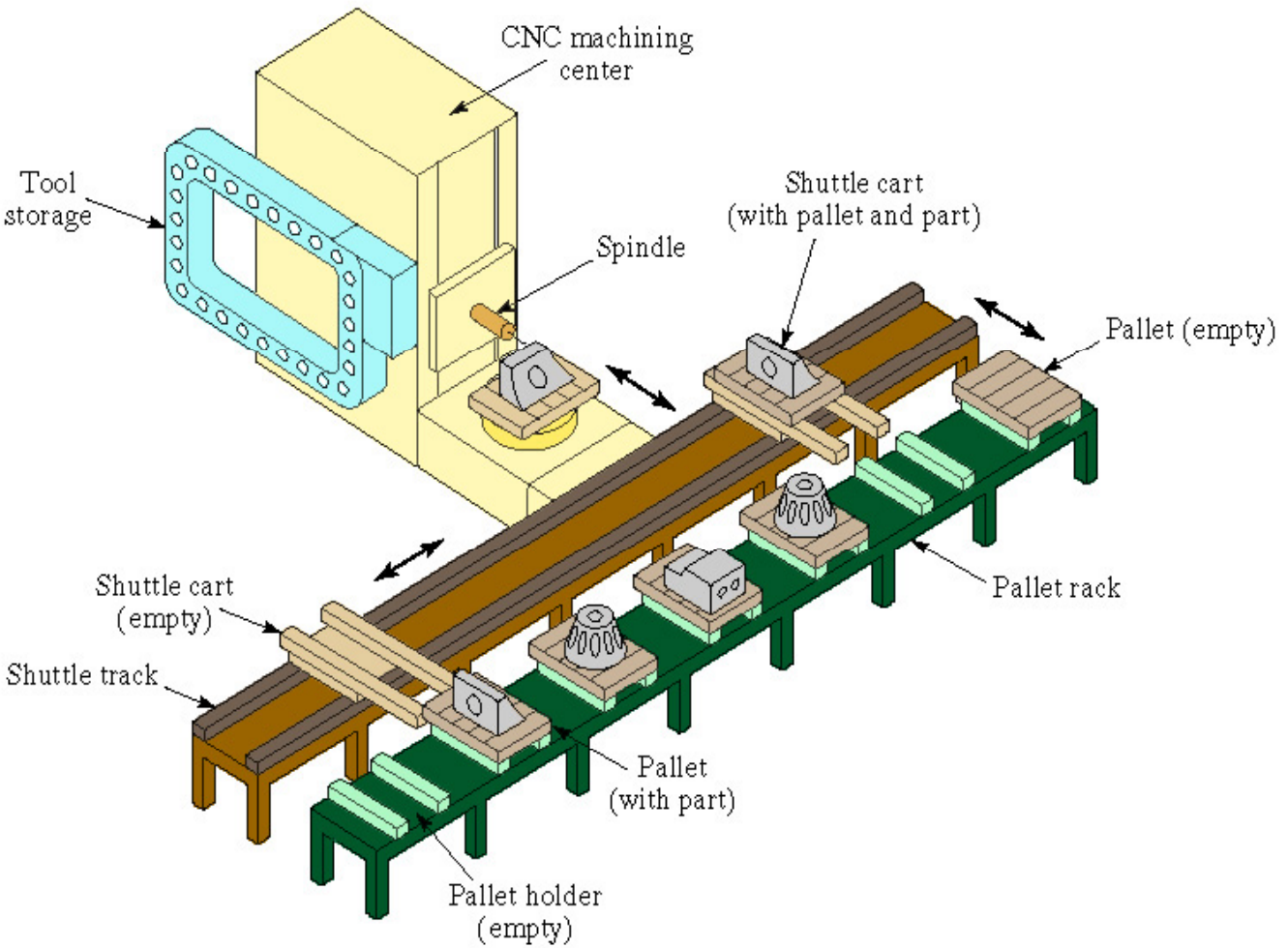

# Flexible Manufacturing Cell

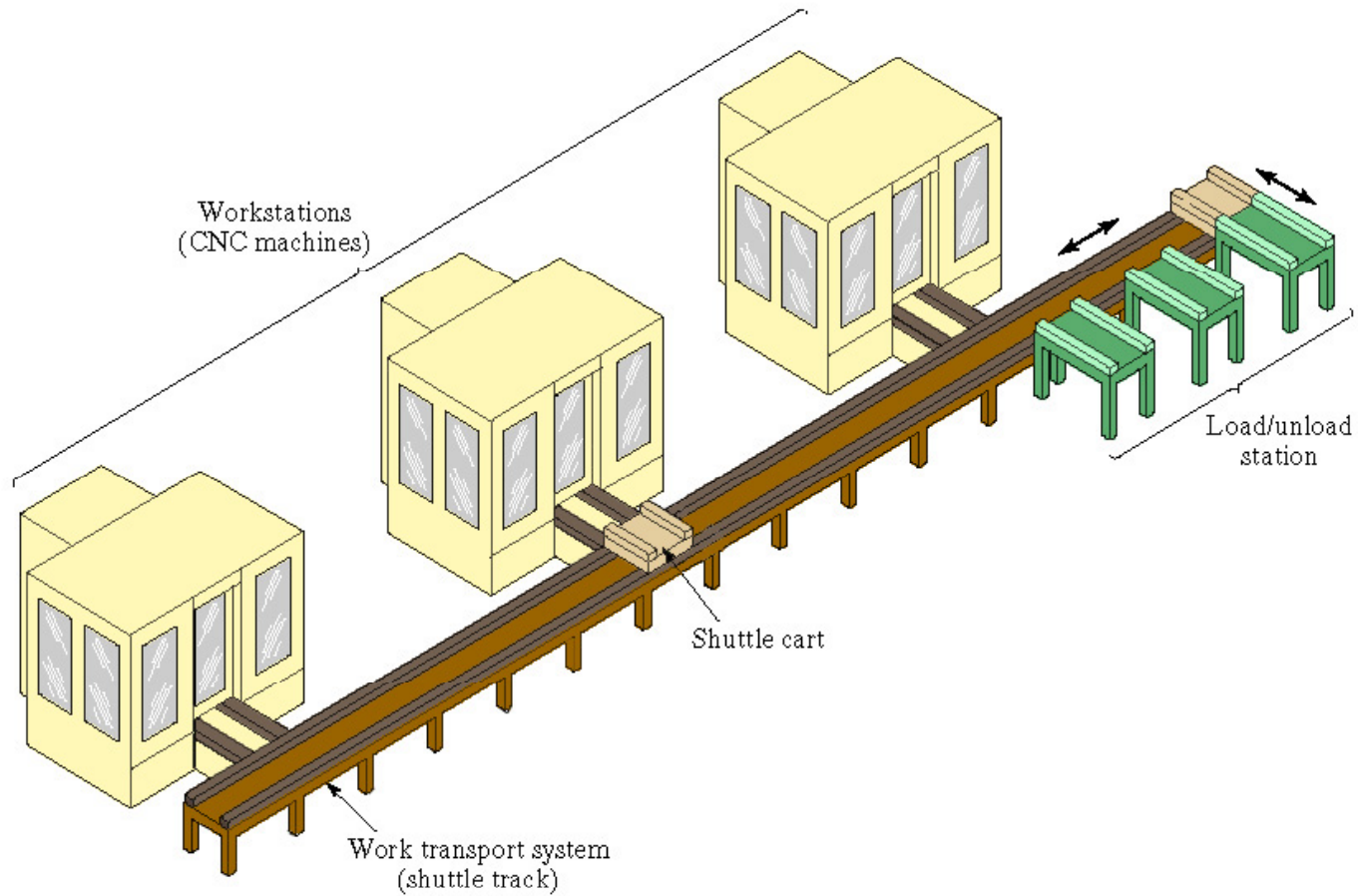

**A two-machine flexible manufacturing cell for machining (photo courtesy of Cincinnati Milacron)**

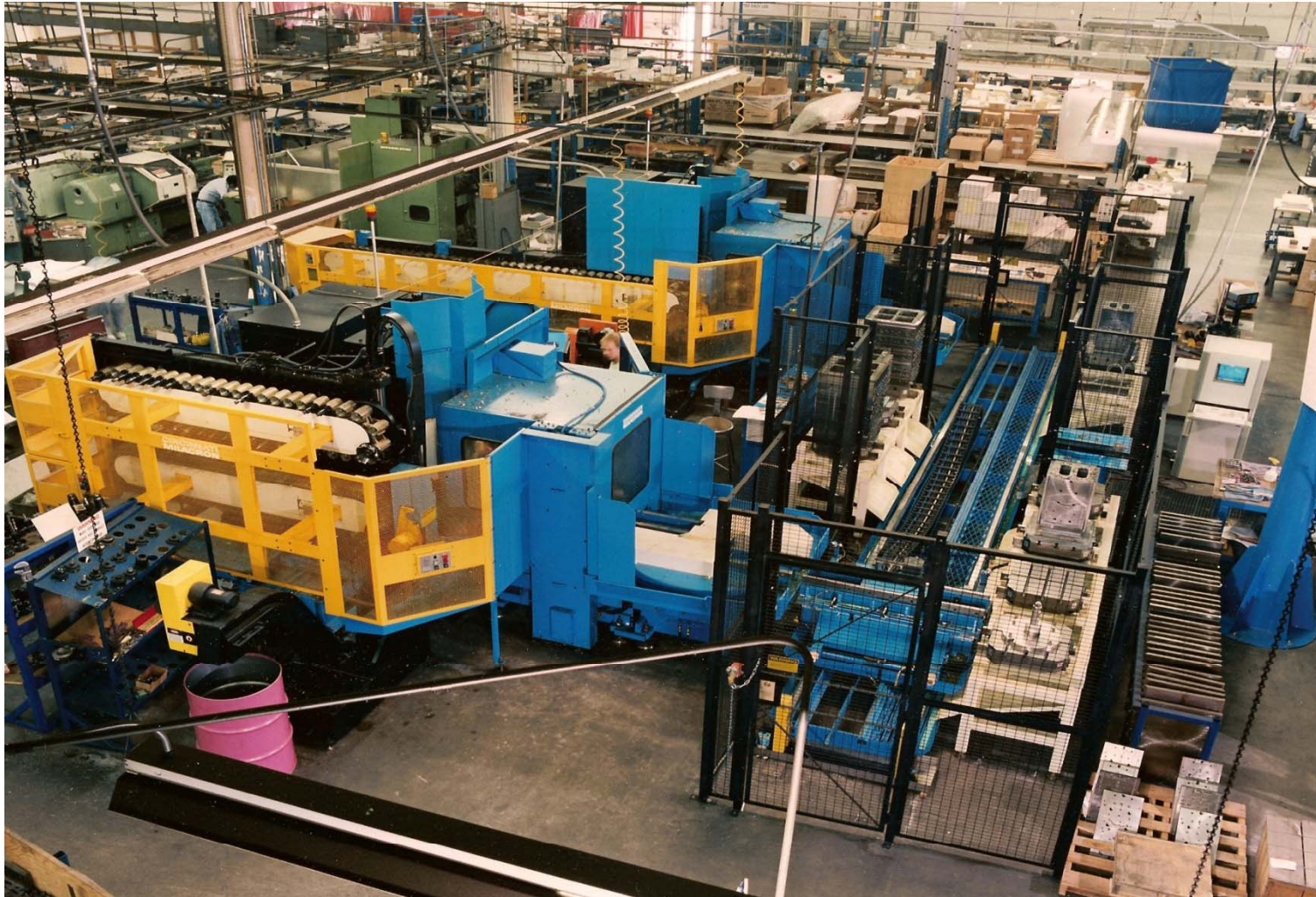

**A five-machine flexible manufacturing system for machining  
(photo courtesy of Cincinnati Milacron)**



# Features of the Three Categories

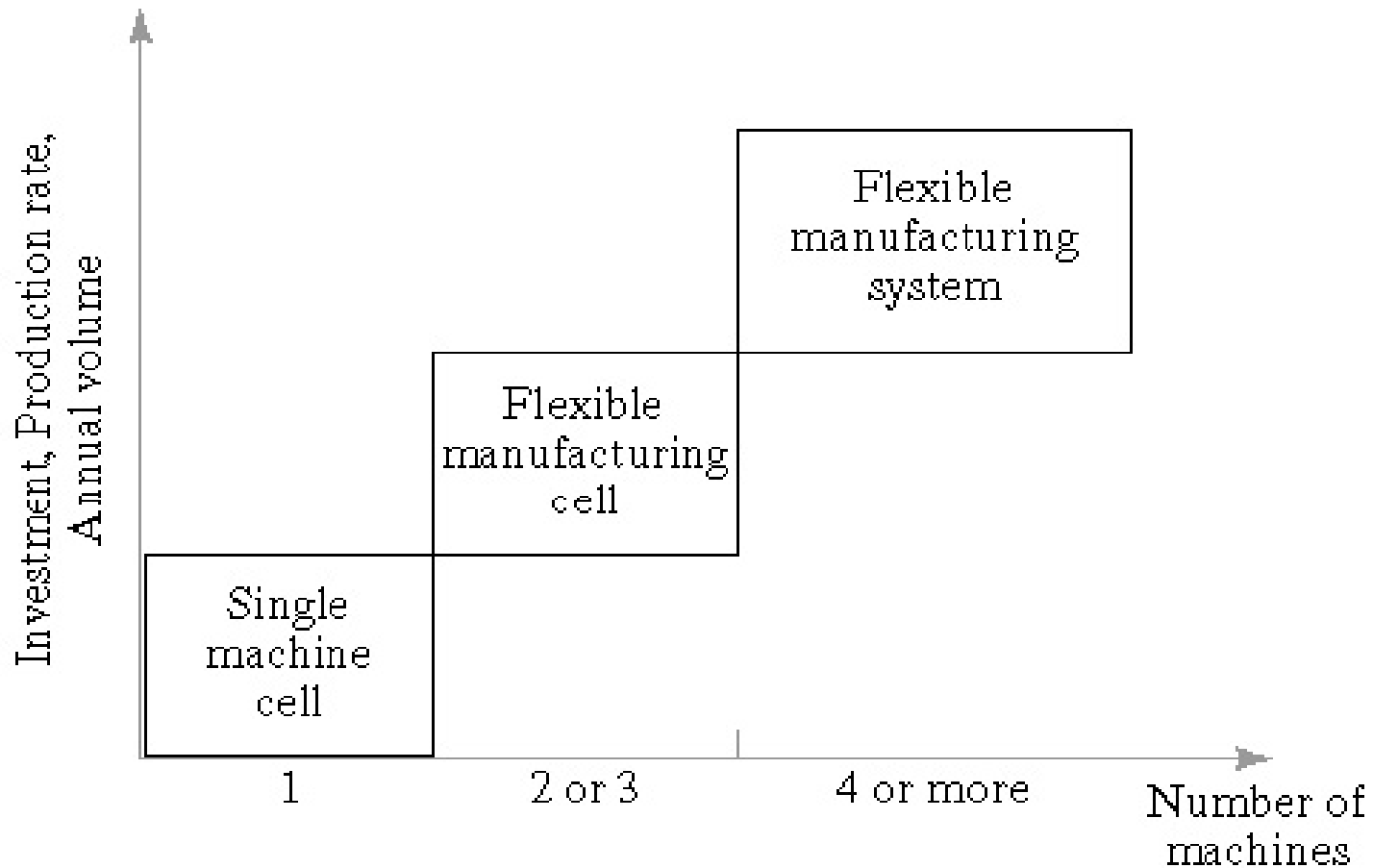

# FMS Types

## Level of Flexibility

### 1. Dedicated FMS

- Designed to produce a limited variety of part styles
- The complete universe of parts to be made on the system is known in advance
- Part family likely based on product commonality rather than geometric similarity

### 2. Random-order FMS

- Appropriate for large part families
- New part designs will be introduced
- Production schedule is subject to daily changes

# Dedicated vs. Random-Order FMSs

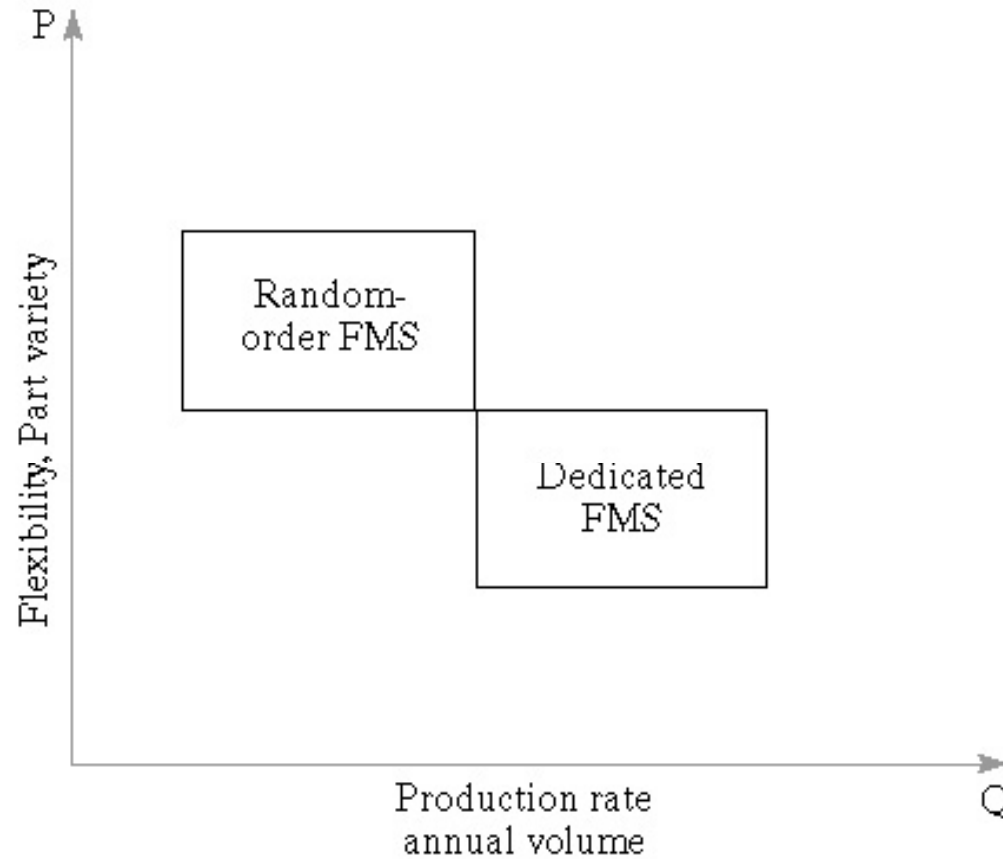

# **FMS Components**

1. Workstations
2. Material handling and storage system
3. Computer control system
4. Human labor



# Workstations

- **Load and unload station(s)**
  - Factory interface with FMS
  - Manual or automated
  - Includes communication interface with worker to specify parts to load, fixtures needed, etc.
- **CNC machine tools in a machining type system**
  - CNC machining centers
  - Milling machine modules
  - Turning modules
- **Assembly machines**

# Material Handling and Storage

- **Functions:**

- Random, independent movement of parts between stations
- Capability to handle a variety of part styles
  - Standard pallet fixture base
  - Work holding fixture can be adapted
- Temporary storage
- Convenient access for loading and unloading
- Compatibility with computer control

# Material Handling Equipment

- Primary handling system establishes basic FMS layout
- Secondary handling system - functions:
  - Transfers work from primary handling system to workstations
  - Position and locate part with sufficient accuracy and repeatability for the operation
  - Reorient part to present correct surface for processing
  - Buffer storage to maximize machine utilization

# Five Types of FMS Layouts

- The layout of the FMS is established by the material handling system
- Five basic types of FMS layouts
  1. In-line
  2. Loop
  3. Ladder
  4. Open field
  5. Robot-centered cell

# FMS In-Line Layout

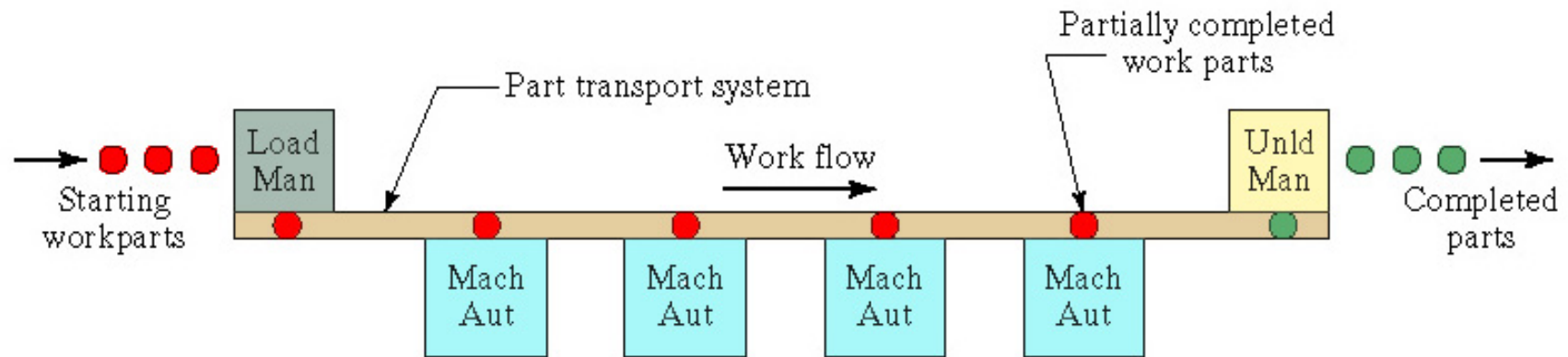

- Straight line flow, well-defined processing sequence similar for all work units
- Work flow is from left to right through the same workstations
- No secondary handling system

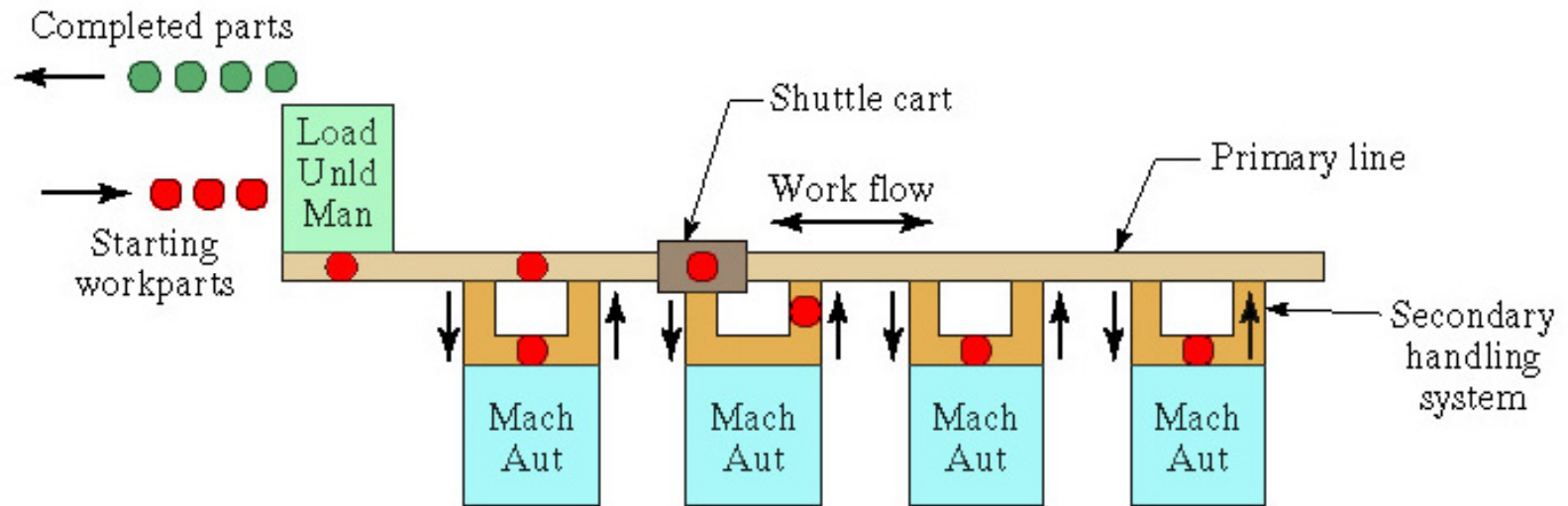

Linear transfer system with secondary parts handling system at each workstation to facilitate flow in two directions

# FMS Loop Layout

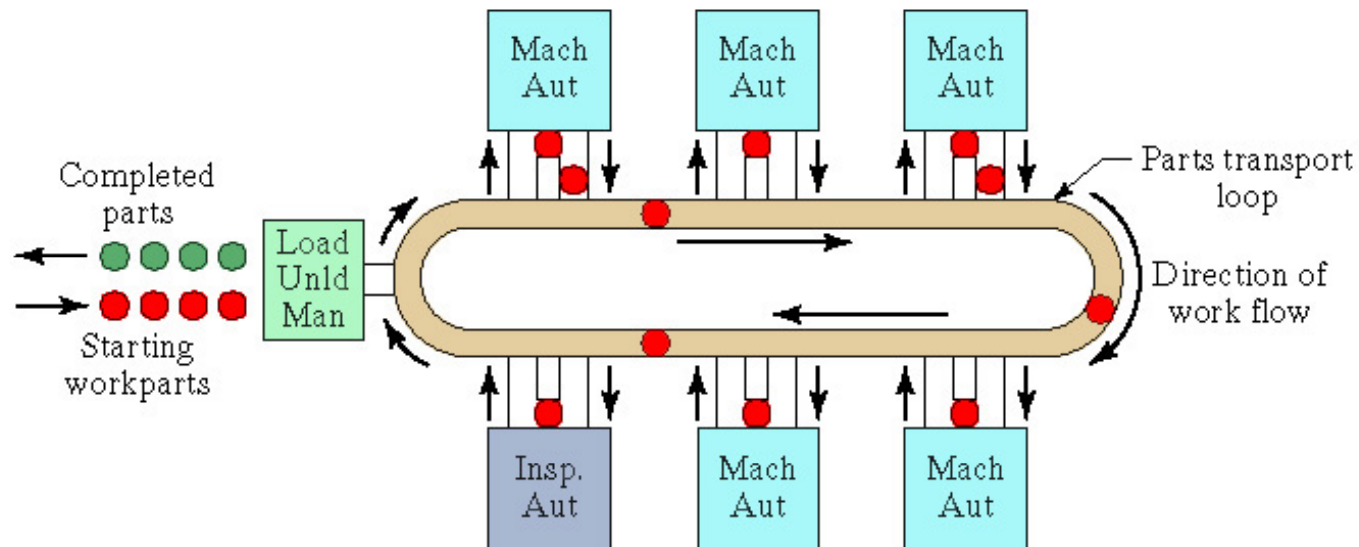

- One direction flow, but variations in processing sequence possible for different part types
- Secondary handling system at each workstation

# FMS Rectangular Layout

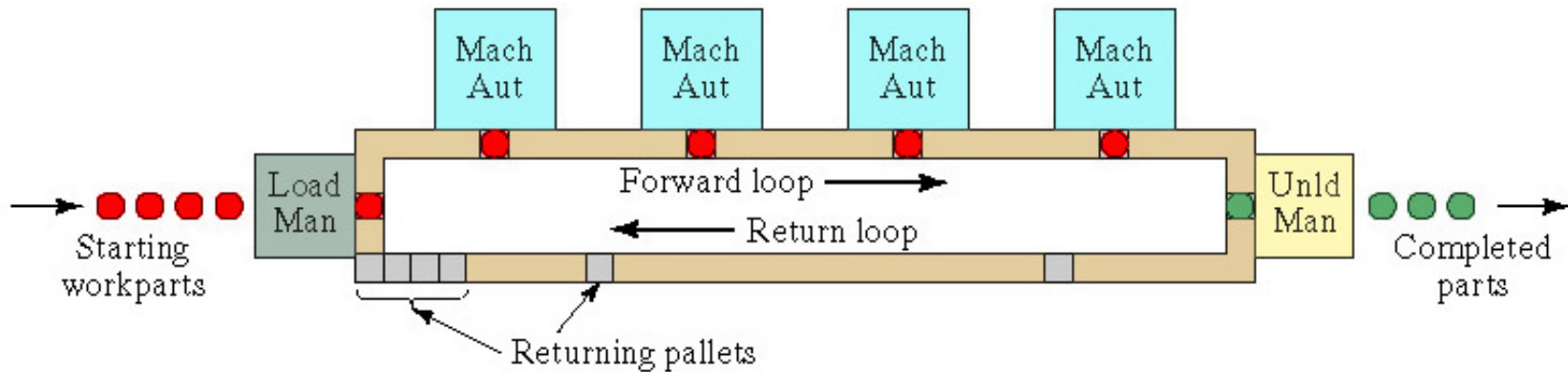

Rectangular layout allows recirculation of pallets back to the first station in the sequence after unloading at the final station



# FMS Ladder Layout

- Loop with rungs to allow greater variation in processing sequence

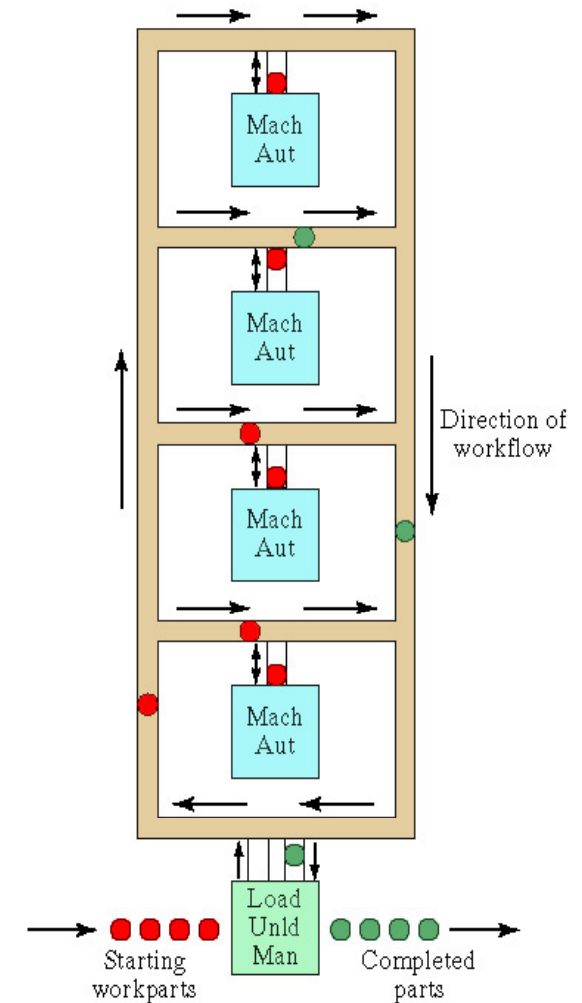

# FMS Open Field Layout

- Multiple loops and ladders, suitable for large part families

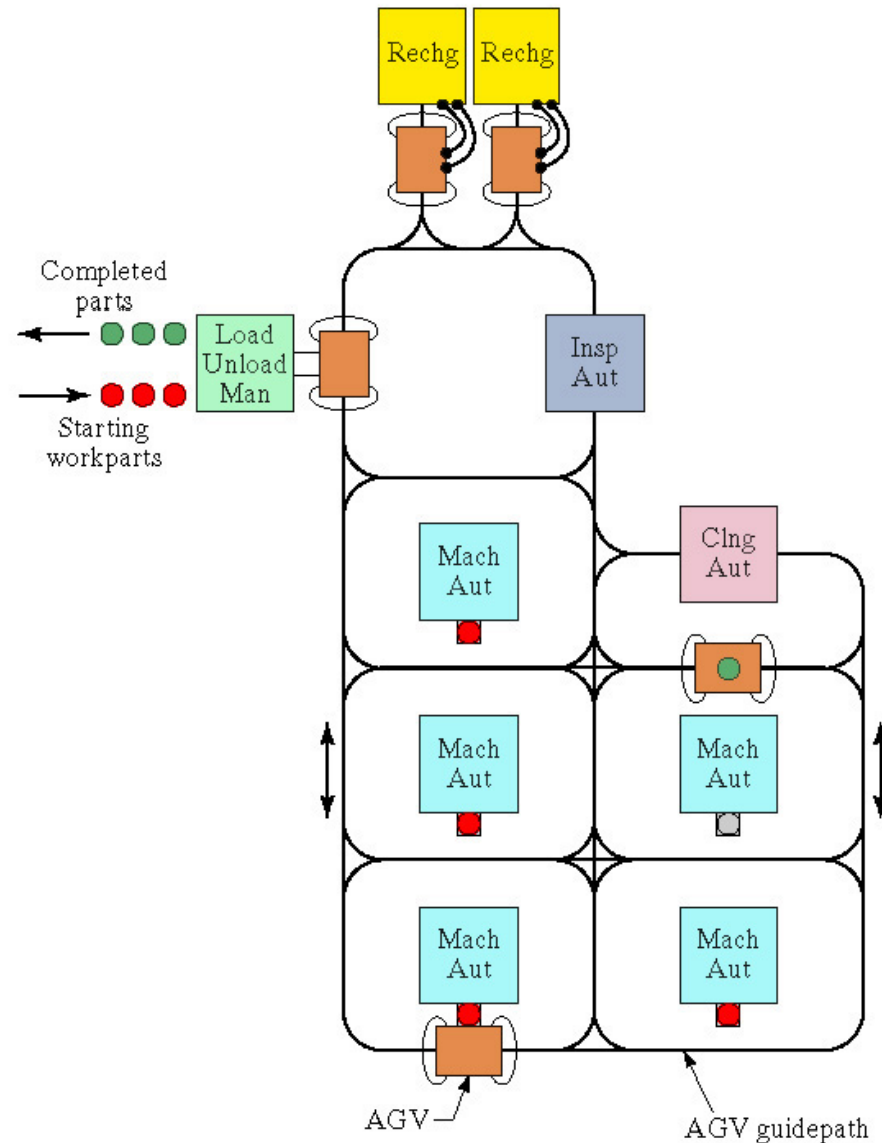

# Robot-Centered Cell

- Suited to the handling of rotational parts and turning operations

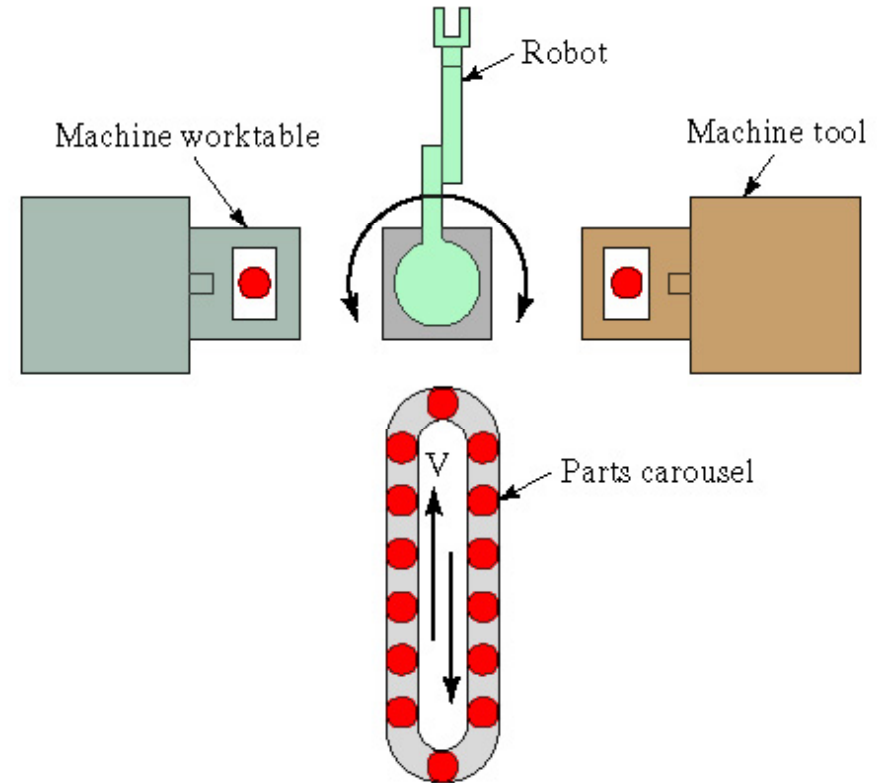

# FMS at Chance-Vought Aircraft

(courtesy of Cincinnati Milacron)

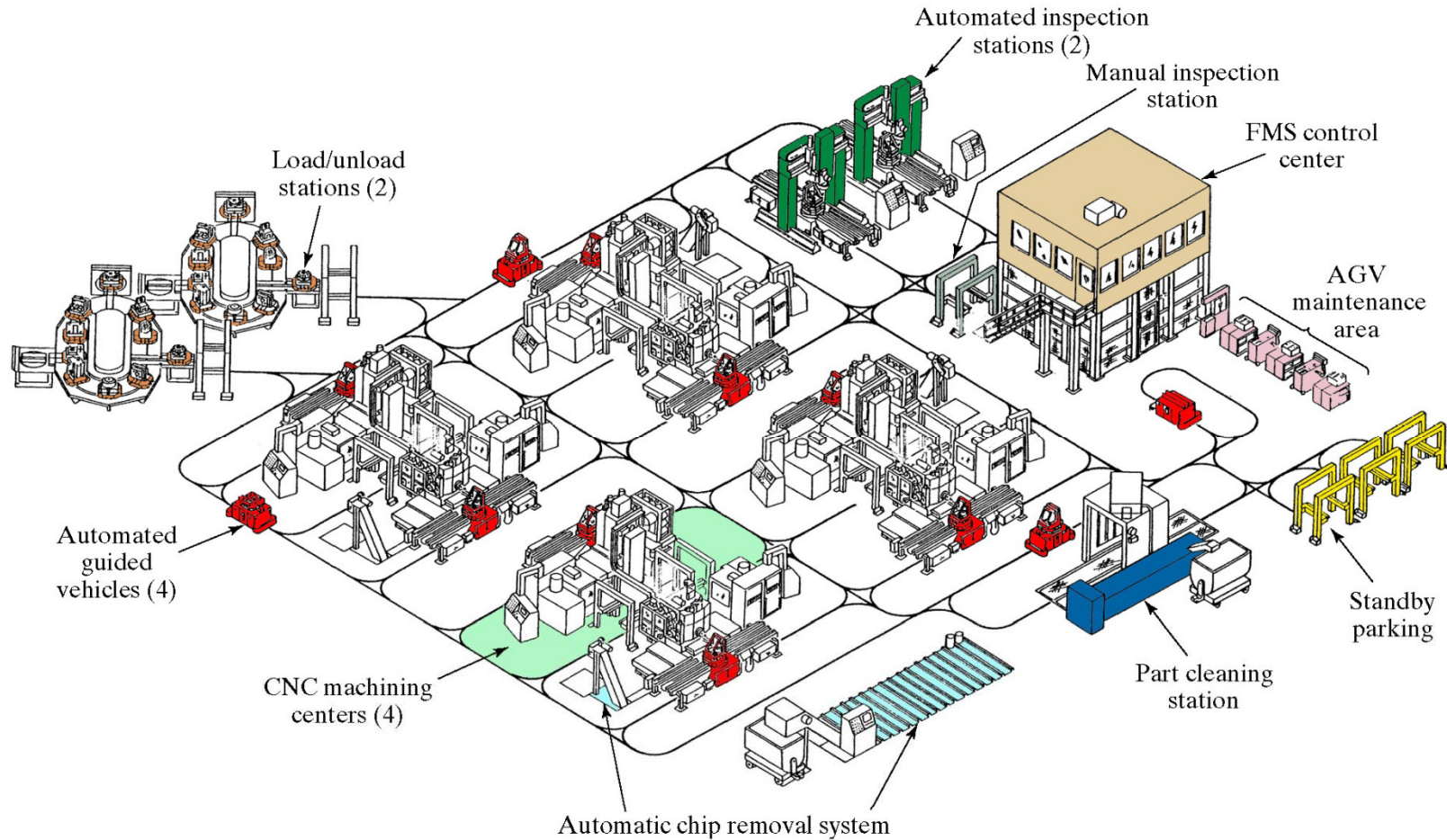

# FMS for Sheet Metal Fabrication

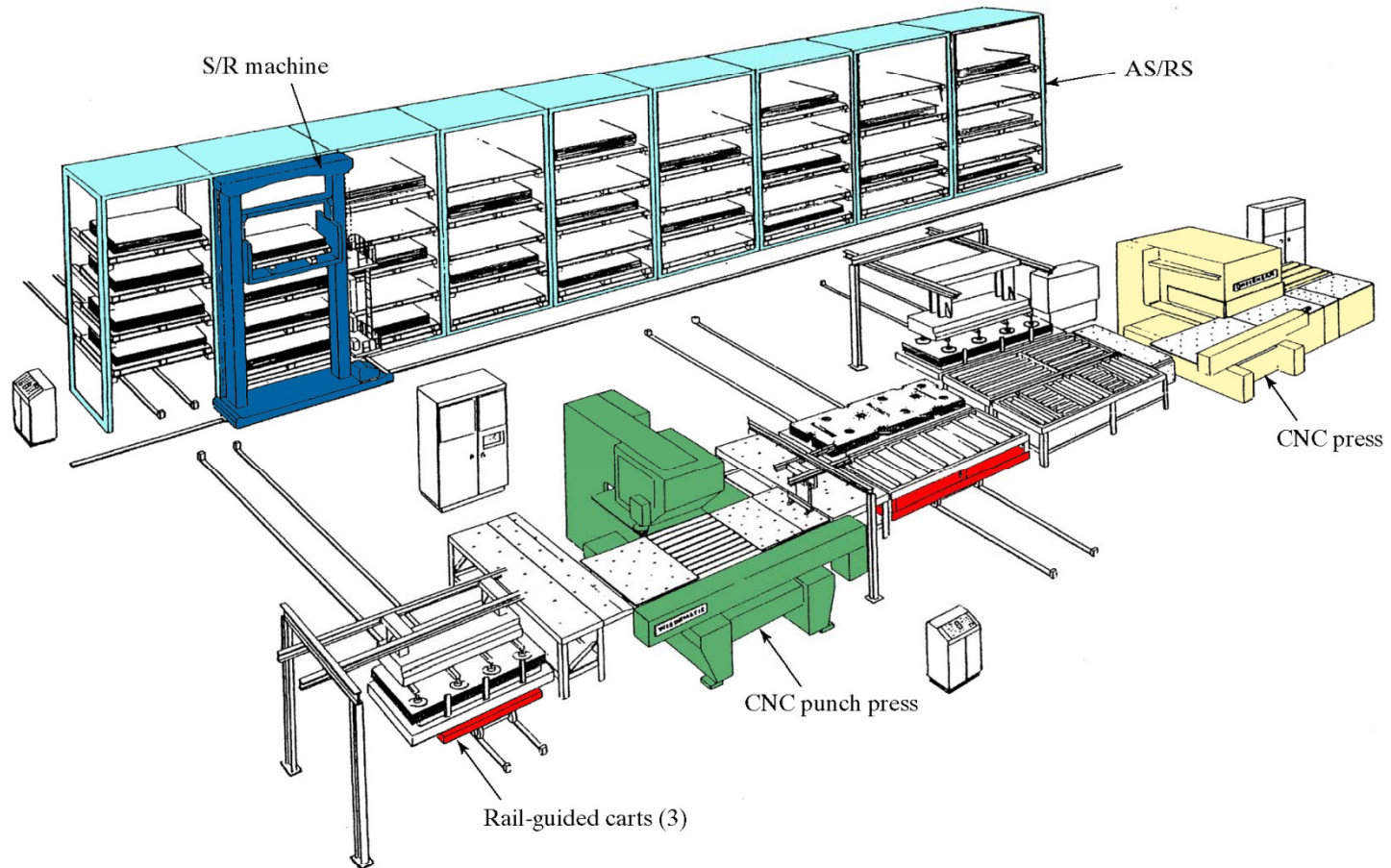

# FMS Benefits

- Increased machine utilization
  - Reasons:
    - 24 hour operation likely to justify investment
    - Automatic tool changing
    - Automatic pallet changing at stations
    - Queues of parts at stations to maximize utilization
    - Dynamic scheduling of production to account for changes in demand
- Fewer machines required
- Reduction in factory floor space required

- Greater responsiveness to change
- Reduced inventory requirements
  - Different parts produced continuously rather than in batches
- Lower manufacturing lead times
- Reduced labor requirements
- Higher productivity
- Opportunity for unattended production
  - Machines run overnight ("lights out operation")

# FMS Planning and Design Issues

- Part family considerations
  - Defining the part family of families to be processed
    - Based on part similarity
    - Based on product commonality
- Processing requirements
  - Determine types of processing equipment required
- Physical characteristics of work parts
  - Size and weight determine size of processing equipment and material handling equipment



- Production volume
  - Annual quantities determined number of machines required
- Types of workstations
- Variations in process routings
- Work-in-process and storage capacity
- Tooling
- Pallet fixtures

# FMS Operational Issues

- Scheduling and dispatching
  - Launching parts into the system at appropriate times
- Machine loading
  - Deciding what operations and associated tooling at each workstation
- Part routing
  - Selecting routes to be followed by each part

- Part grouping
  - Which parts should be on the system at one time
- Tool management
  - When to change tools
- Pallet and fixture allocation
  - Limits on fixture types may limit part types that can be processed

# Quantitative Analysis of Flexible Manufacturing Systems

- **FMS analysis techniques:**
  1. Deterministic models
  2. Queueing models
  3. Discrete event simulation
  4. Other approaches, including heuristics
- **Deterministic models**
  1. **Bottleneck model** - estimates of production rate, utilization, and other measures for a given product mix
  2. **Extended bottleneck model** - adds work-in-process feature to basic model

# **Quantitative Analysis of Bottleneck model**

# Bottleneck Model

- In this model, output of production system has an upper limit, given that the product mix flowing through the system is **FIXED**.

**1. Product mix:** 
$$\sum_{j=1}^P p_j = 1.0$$

$p_j$  = fraction of total system output of style  $j$ .

$P$  = total number of different parts styles made in the FMS during period of interest.

2. **Workstation and Servers**: it is possible to have two or more machines capable of performing the same operations.

$s_i$  = number of servers at workstation  $i$ , where  $i = 1, 2, \dots, n$ .

3. **Process routing**: the process routing defines sequence of operations, the w/stn at which they are performed and associated processing times.  $t_{ijk}$  = Processing time which is total time that a production unit occupies a given w/stn server.  $i$  = station;  $j$  = part or product;  $k$  = sequence of operation

4. **Work handling system**: work handling system is designated as  $n+1$  and  $s_{n+1}$  = number of carriers in the FMS handling system.
5. **Transport time**:  $t_{n+1}$  = the mean transport time required to move a part from one w/stn to next stn in the process routing.
6. **Operation frequency**: it is defined as the expected number of times a given operation in the process routing is performed for each work unit. eg. An inspection is performed once every four units, the freq = 0.25.  $f_{ijk}$  = operation freq for operation  $k$  in the process plan  $j$  at stn  $i$ .



# 1. FMS Operational Parameters

The average work load for the given station is defined as the mean total time spent at the station per part. It is calculated as:

$$WL_i = \sum_j \sum_k t_{ijk} f_{ijk} p_j$$

$WL_i$  = average work load for station  $i$  (min),

$t_{ijk}$  = processing time for operation  $k$  in the process  $j$  at station  $i$  (min),

$f_{ijk}$  = operation freq for oper  $k$  in part  $j$  at stn  $i$ .

$p_j$  = part mix fraction for part  $j$ .

The average number of transports is equal to the mean number of operations in the process routing minus one.

$$n_t = \sum_i \sum_j \sum_k f_{ijk} P_j - 1$$

$n_t$  = mean number of transports

Computing the work load of the handling system:

$$WL_{n+1} = n_t t_{n+1}$$

$WL_{n+1}$  = work load of handling system (min),

$n_t$  = mean number of transports

$t_{n+1}$  = mean transport time per move (min)

## 2. System Performance Measures

**Assumptions:** 1. FMS producing at max possible rate; 2. Rate is constrained by bottleneck station in the system (highest workload per server).

Work load per server is

$$WL_i / s_i$$

The bottleneck is identified by finding max value of the ratio among all stations.

Let  $WL^*$ ,  $s^*$ ,  $t^*$  equal to WL, No. of servers, processing time for the bottleneck station resp

FMS max production rate of all parts is

$$R_p^* = \frac{S^*}{WL^*}$$

The above equation is valid if product mix is constant.

Individual part production rates can be obtained by multiplying  $R_p^*$  by the respective part mix ratios.

$$R_{pj}^* = p_j (R_p^*) = p_j \frac{S^*}{WL^*}$$

$R_{pj}^*$  = max prod rate of part style  $j$  (pc/min)  
and  $p_j$  = part mix fraction for style  $j$

The **mean utilization** of each workstation is the **proportion of time that the servers at the station are working and not idle.**

$$U_i = \frac{WL_i}{s_i} (R_p^*) = \frac{WL_i}{s_i} \cdot \frac{s^*}{WL^*}$$

$U_i$  = Utilization of station  $i$ ,  $WL_i$  = workload of station  $i$  (min/pc),  $s_i$  = number of servers at workstations  $i$ , and  $R_p^*$  = overall production rate (pc/min). **The utilization of the bottleneck station is 100% at  $R_p^*$**

The **average station utilization** including transport system as

$$\bar{U} = \frac{\sum_{i=1}^{n+1} U_i}{n+1} \quad \bar{U} = \text{is an unweighted average of all workstations utilization.}$$

Useful measure is **overall FMS utilization** which is based on number of servers at each station

$$\bar{U}_s = \frac{\sum_{i=1}^n s_i U_i}{\sum_{i=1}^n s_i} \quad \bar{U}_s = \text{overall FMS utilization}$$

Number of **busy servers** at each station is

$$BS_i = WL_i (R_p^*) = WL_i \frac{s^*}{WL^*}$$

$BS_i$  = number of busy servers on average at station  $i$ , and  $WL_i$  = workload at station  $i$ .

# Problem 1

A flexible manufacturing cell consists of two machining workstations plus a load/unload station. The load/unload station is station 1. Station 2 performs milling operations and consists of one server (one CNC milling machine). Station 3 has one server that performs drilling (one CNC drill press). The three stations are connected by a part handling system that has one work carrier. The mean transport time is 2.5 min. The FMC produces three parts, A, B, and C. The part mix fractions and process routings for the three parts are presented in the table below. The operation frequency  $f_{ijk} = 1.0$  for all operations.

## Determine:

- a) Maximum production rate of the FMC,
- b) Corresponding production rates of each product
- c) Utilization of each machine in the system,
- d) Number of busy servers at each station.



Part $j$	Part mix $p_j$	Operation $k$	Description	Station $i$	Process time $t_{ijk}$
A	0.2	1	Load	1	3 min
		2	Mill	2	20 min
		3	Drill	3	12 min
		4	Unload	1	2 min
B	0.3	1	Load	1	3 min
		2	Mill	2	15 min
		3	Drill	3	30 min
		4	Unload	1	2 min
C	0.5	1	Load	1	3 min
		2	Drill	3	14 min
		3	Mill	2	22 min
		4	Unload	1	2 min

# Solution

$$a) \quad WL_i = \sum_j \sum_k t_{ijk} f_{ijk} P_j$$

$$WL_1 = (3+2)(0.2)(1.0) + (3+2)(0.3)(1.0) + (3+2)(0.5)(1.0) = 5.0 \text{ min}$$

$$WL_2 = 20(0.2)(1.0) + 15(0.3)(1.0) + 22(0.5)(1.0) = 19.5 \text{ min}$$

$$WL_3 = 12(0.2)(1.0) + 30(0.3)(1.0) + 14(0.5)(1.0) = 18.4 \text{ min}$$

$$n_t = \sum_i \sum_j \sum_k f_{ijk} P_j - 1$$

$$n_t = 3(0.2)(1.0) + 3(0.3)(1.0) + 3(0.5)(1.0) = 3,$$

$$WL_{n+1} = n_t t_{n+1}$$

$$WL_4 = 3(2.5) = 7.5 \text{ min}$$

Bottleneck station has largest  $WL_i/s_i$  ratio

Station	$WL_i/s_i$ ratio
1 (load/unload)	$5.0/1 = 5.0 \text{ min}$
2 (mill)	$19.5/1 = 19.5 \text{ min}$ ← Bottleneck
3 (drill)	$18.4/1 = 18.4 \text{ min}$
4 (material handling)	$7.5/1 = 7.5 \text{ min}$

$$R_p^* = \frac{s^*}{WL^*}$$

Bottleneck is station 2:  $R_p^* = 1/19.5 = 0.05128$  pc/min = **3.077 pc/hr**

Individual part production rates can be obtained by multiplying

$$R_{pj}^* = p_j (R_p^*) = p_j \frac{s^*}{WL^*}$$

b)  $R_{pA} = 0.05128(0.2) = 0.01026$  pc/min = **0.6154 pc/hr**

$$R_{pB} = 0.05128(0.3) = 0.01538$$
 pc/min = **0.9231 pc/hr**

$$R_{pC} = 0.05128(0.5) = 0.02564$$
 pc/min = **1.5385 pc/hr**

$$U_i = \frac{WL_i}{s_i} (R_p^*) = \frac{WL_i}{s_i} \cdot \frac{s^*}{WL^*}$$

$$U_1 = (5.0/1)(0.05128) = 0.256 = \mathbf{25.6\%}$$

$$U_2 = (19.5/1)(0.05128) = 1.0 = \mathbf{100\%}$$

$$U_3 = (18.4/1)(0.05128) = 0.944 = \mathbf{94.4\%}$$

$$U_4 = (7.5/1)(0.05128) = 0.385 = \mathbf{38.5\%}$$

$$BS_i = WL_i (R_p^*) = WL_i \frac{s^*}{WL^*}$$

$$BS1 = (5.0)(0.05128) = 0.256 \text{ servers}$$

$$BS2 = (19.5)(0.05128) = 1.0 \text{ servers}$$

$$BS3 = (18.4)(0.05128) = 0.944 \text{ servers}$$

$$BS4 = (7.5)(0.05128) = 0.385 \text{ servers}$$

# Summary

- Basics of FMS
- Types and Layouts
- Issues for Implementation
- Quantitative Analysis: Bottleneck Model with operational and system design issues
- Solve Problem **End of Chapter** to grasp concept
- Extended Bottleneck (next lecture)